



9000 kitchen mixer

The FM Mattsson 9000 kitchen mixer has a harmonious, classic design. Standard features include a hot water lock, adjustable flow control, a soft-close mechanism and a ceramic seal. These features eliminate the risk of scalding, and protect the pipes by preventing water hammering. With its popular, user-friendly design, this has been Sweden's best selling mixer for many years.

Article number: 91510000

Description: Chrome, with CU Ø10 mm

Unique characteristics

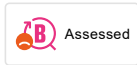

Backflow protection unit type

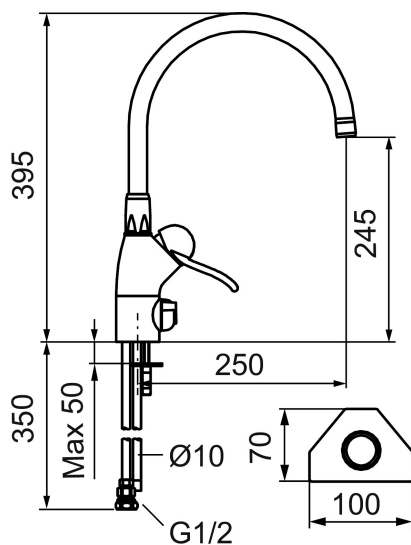

- Ceramic cartridge with soft closing function
- Adjustable flow control and temperature limiter
- Swivel spout 110°, Ø22 mm
- With dish washer valve, switchable between cold and hot water. Pre-set on cold water
- Hole diameter Ø28-37 mm