

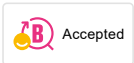

Unique characteristics

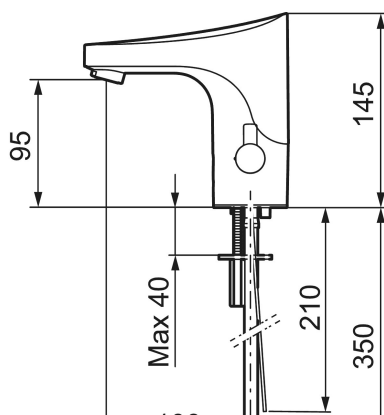

Backflow protection unit type



9000E tronic WMS basin mixer, mains operation

Article number: 16416100

Description: Chrome, mains operation (without transformer), 5 l/min at 200–600 kPa

- WMS-mixers with possibilities of wireless connection
- Soft closing solenoid valve
- Safe against vandalism, complete in metal
- Eco (energy and water saving constant flow aerator)
- Flush Timeout - safety shut-off to prevent flooding
- Rinse time
- Time limited shut-off (eg for cleaning)
- Low power consumption - Long life
- Equipped with function for thermal disinfection against legionella
- Mains operation (excl. transformer)
- IP class sensor, IP67
- Approved non-return valves, EN-Standard EN1717
- Environmental friendly material, Lead free, Nickel Free

Installation:

- Automatic sensor calibration
- After adjusting to the desired temperature, knob can be replaced with a lid
- Mains operation requires power supply art.no. S600129, alternatively transformer art.no. S600128
- Soft PEX[®] hoses with integrated non return valves and filters (stainless steel braided)
- Hole diameter Ø33,5-37 mm

Tronic WMS:

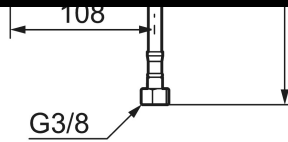

- With wireless connection to the Tronic WMS system (gateway and subscription required) alternatives via Dongel (1616-1000) the following opportunities are obtained:
 - Programmable rinsing time from 10–60 seconds
 - Built-in temperature measurements (measures output water temperature)
 - Programmable temperature stop, the mixer will turn off directly at set maximum temperature
 - Flush time control, prevents overflow, maximum flush time 5 min.
 - Adjustable hygiene flushing, interval and flush time (to prevent water becoming stagnant)
 - Logging of all flushings with point of time, water consumption and temperature. - Only with WMS
 - Stagnation alarm (an alarm is emitted if the unit is not used within the set time) – Only with WMS
 - Alarm via SMS or email – Only with WMS