



## 9000XE shower mixer

9000XE shower mixer in chrome is the successor to one of our best-selling mixers. Its design is as sophisticated as that of its predecessor, but it has been upgraded with double check valves, faster temperature regulation, lower weight and noise absorbing functions.

**Article number:** 86800000 **Flow 3 bar:** 12.2 l/m

**Description:** Chrome, 160 c/c

### Unique characteristics



Backflow protection unit type 

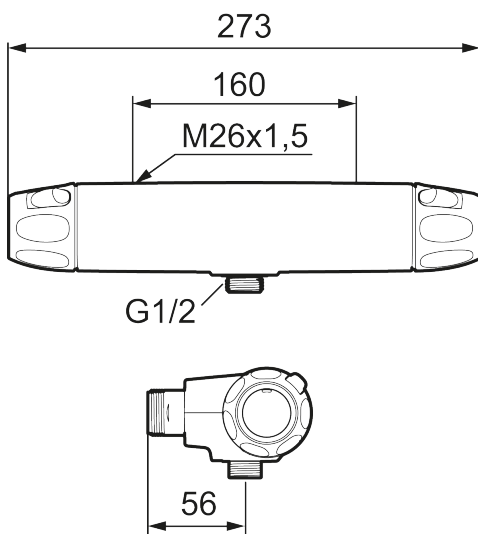

- With shower connection down
- Pressure balanced thermostatic mixer
- With ceramic sealed headwork
- Temperature handle with safety stop at 38°C
- With Eco-function
- Lead Free material
- Approved non-return valves, EN-Standard EN1717