

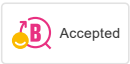

Unique characteristics

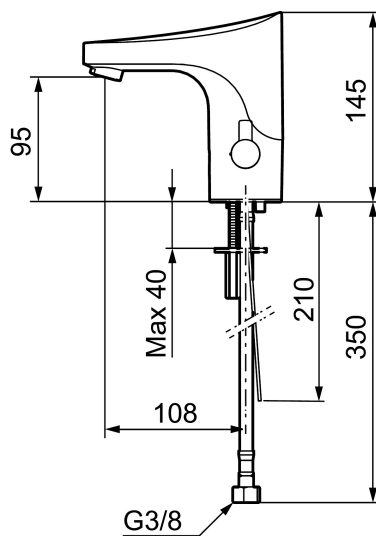

Backflow protection unit type **EB**



## MEDICARE tronic WMS basin mixer , battery operation

The touch-free MEDICARE Tronic WMS basin mixer satisfies all hygiene requirements in the market. Made from a lead-free material, it has a smooth, clean-lined design. Joints have been kept to a minimum for easier cleaning and use. The connection tubes have new protective sleeving and the aerator has no air admixture, thus reducing the risk of spreading bacteria. The sensor-controlled function improves hygiene by allowing you to use your tap without touching it.

And to obtain even more advanced functionality, the mixer can be connected to our innovative digital cloud service, Tronic WMS. This allows the mixers to be monitored, analysed and evaluated, providing valuable information which can be used to improve operation and use.

[Read more about the benefits of connected mixers.](#)

### About the collection

The FM Mattsson MEDICARE collection has been designed in close collaboration with healthcare experts. The MEDICARE collection places emphasis on hygiene, accessibility and sustainability and is designed to meet the specific needs of the healthcare sector while making daily life easier for users with impaired mobility or orientation capacity.

Article number: 16414000 Flow 3 bar: 4.9 l/m

Description: Chrome, battery operation, included battery

- Aerator without air admixture, constant flow at 200–600 kPa
- Flexible connection tubes in stainless steel braided Soft PEX® with 3/8" connecting nut, with protective plastic covering for improved hygiene and easier cleaning
- Hygienic design, joints kept to a minimum
- WMS mixer tap with the option of wireless connection to our Tronic WMS system or programming via a dongle.
- Hygiene flushing function for minimising bacterial growth in the water system.
- Soft closing solenoid valve
- Flush Timeout - safety shut-off to prevent flooding
- Rinse time
- Cleaning mode, time-limited shut-off for cleaning

- Low power consumption - Long life
- Equipped with system for thermal disinfection against legionella
- IP class sensor, IP67
- Approved non-return valves, EN-Standard EN1717
- Environmental friendly material, Lead free, Nickel Free

**Installation:**

- Temperature knob can be removed and replaced with a cover (included)
- Battery operation, adaptable for mains operation
- For mains operation requires installation of the adapter kit FMM S600147
- Hole diameter Ø33,5-37 mm

**Functions via Tronic WMS/dongle:**

- Programmable of:
  - Flush Timeout
  - Rinse time
  - Hygiene flushing, interval and flush time
  - Maximum temperature
  - Initiation of thermal disinfection
- Additional functions with Tronic WMS:
  - Operational monitoring (flushings, water consumption and temperature, battery status, etc.)
  - Logging of all events
  - Alarm via SMS or email
  - Documentation and report function