



9000E bath mixer

An optimal fusion of design and function. The FM Mattsson 9000E range ushers in a new generation of mixers that are environmentally engineered down to the last detail. The mixer brings beauty and technical perfection. Even in its basic version, the mixer has unique functions that save energy without compromising on comfort.

Article number: 81900000

Description: Chrome, 160 c/c

- Soft closing with ceramic cartridge
- Swivel spout with built-in diverter
- Approved non-return valves, EN-Standard EN1717

Unique characteristics

Backflow protection unit type  EB

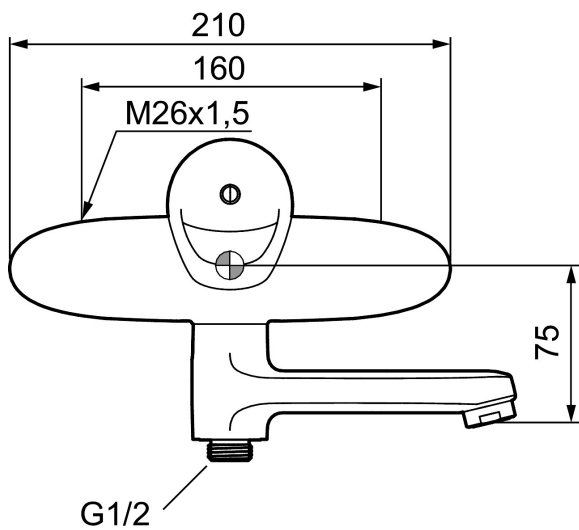

PRODUCT DESCRIPTION

9000E bath mixer

An optimal fusion of design and function. The FM Mattsson 9000E range ushers in a new generation of mixers that are environmentally engineered down to the last detail. The mixer brings beauty and technical perfection. Even in its basic version, the mixer has unique functions that save energy without compromising on comfort.

Article number: 81900000

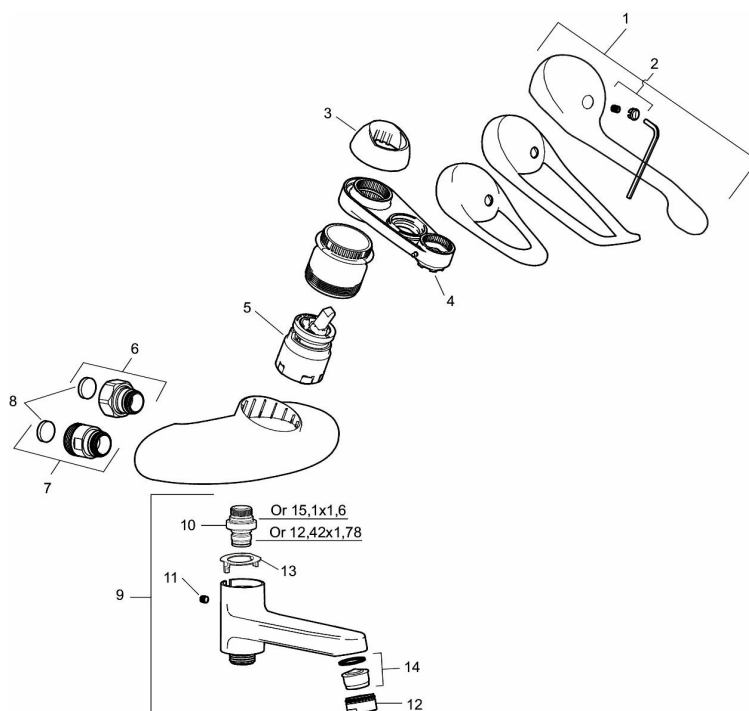

Sparepartlist

NO.	FMM NO.	RSK	DESCRIPTION
1	58500000	8591936	Lever, complete, L=90 mm
1	58501750	8591937	Lever, complete, L=150 mm
1	58501800	8592048	Lever, complete, L=180 mm
2	58510000	8591944	Cover lid with colour marking
3	58520000	8591945	Cover sleeve
4	S600298	3870203	Service tool
5	S600276	8387231	Ceramic cartridge, incl. service tool, 20 l/min
6	59811800	8592011	Inlet connectors 150 c/c (left-handed thread)
7	59800800	8592005	Inlet connectors, 160 c/c
8	38680009	8591701	Filter kit incl. o-rings and service tool
9	82990000	8154073	Swivel spout with integrated diverter
10	39754000	8591969	Nipple M18x1 with o-ring for bath mixer

NO.	FMM NO.	RSK	DESCRIPTION
11	38086000	8439701	Locking screw
12	29142400	8281526	Housing M24 ext., 13 mm
13	38521000	8295345	Stop ring
14	29102650	8281547	Aerator insert, 20–24 l/min at 300 kPa